

SIRIUS



Sirius

Sirius S.p.a., established in 1996, operates in the market sector of residential air ventilation and purification, in particular it produces cooker hoods for residential kitchens. Quality, innovation, professional competence, technology and design are rolled into one with a clear and dynamic commercial policy that has permitted a rapid growth of the company, ensuring market penetration throughout the world.

Sirius has, in a short time, become a world leader in the sector of high quality decorative cooker hoods, encompassing a wide product range and exporting 90% of its production. The strategic choices accomplished in the technical productivity sectors, dictated by many years of experience, have been of fundamental importance for the growth and success of the company.

A wide range of products, different technological possibilities and innovation, functionality of the components used, such as the motors, and different ventilation components represent a combination between design and functionality. This gives the clients a wide choice, to meet all of their ventilation needs. Our company's philosophy, innovative in the market of residential kitchen ventilation, aims to maintain and improve the high quality standards of our production in style, technology and design, which are synthesized by the realization of modular and innovative ventilation systems.



Sirius
● ○ ●

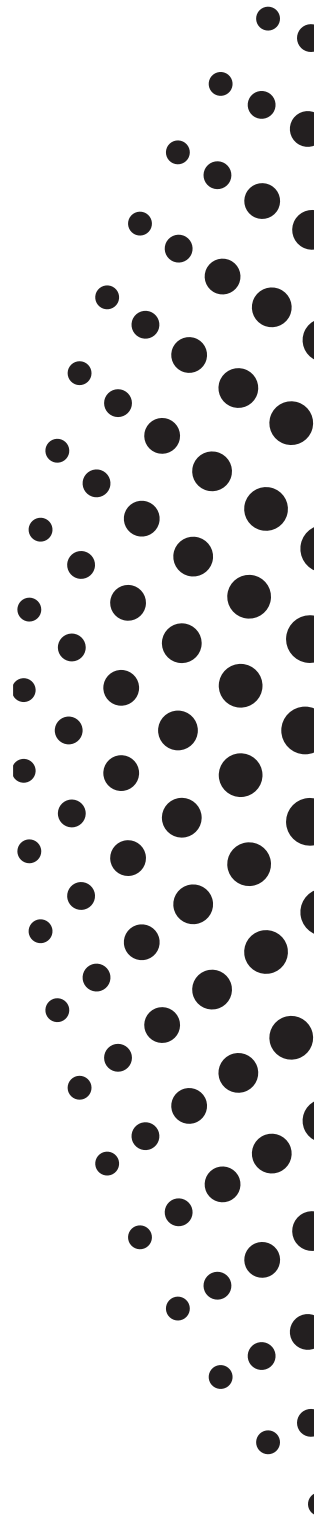

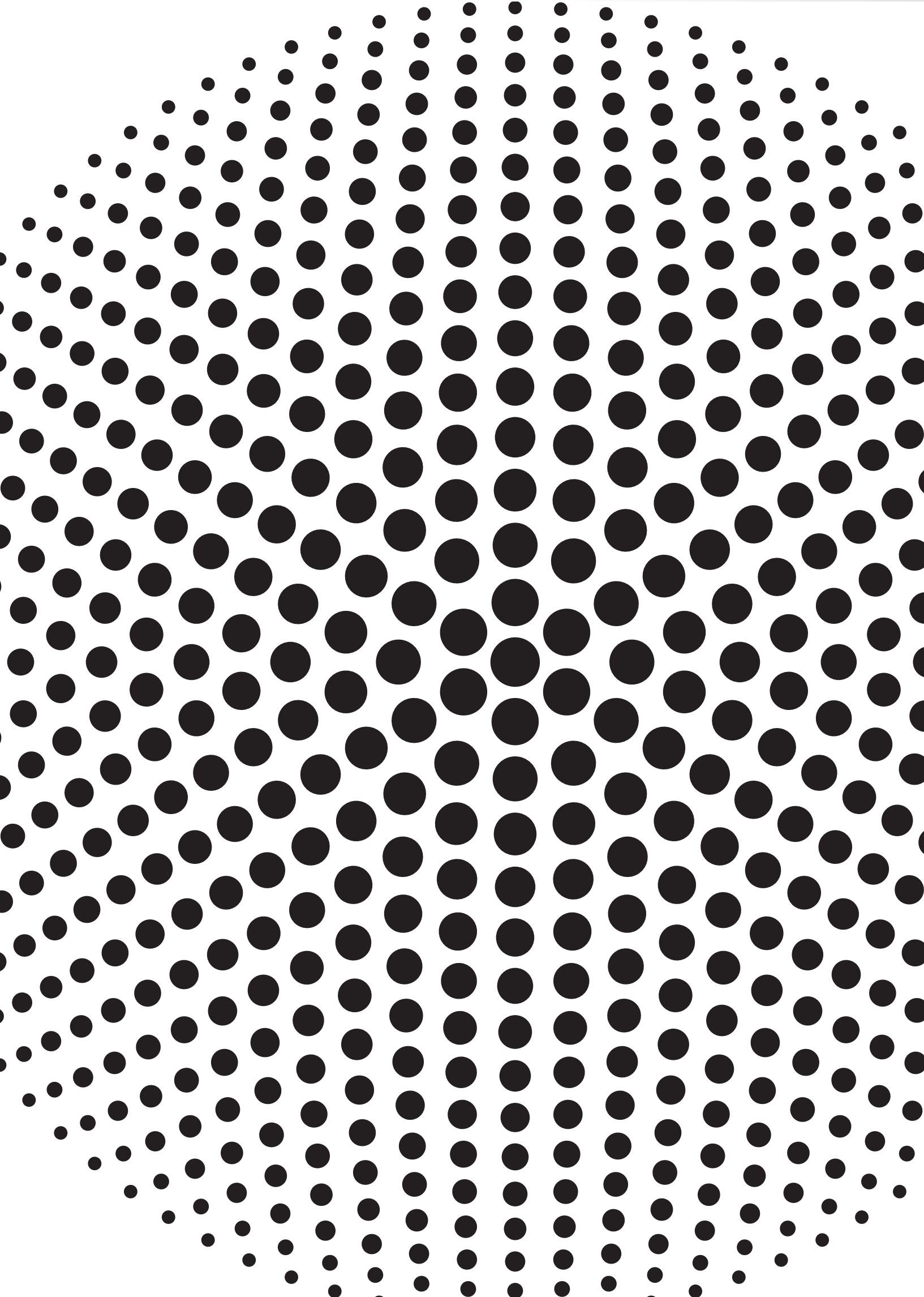

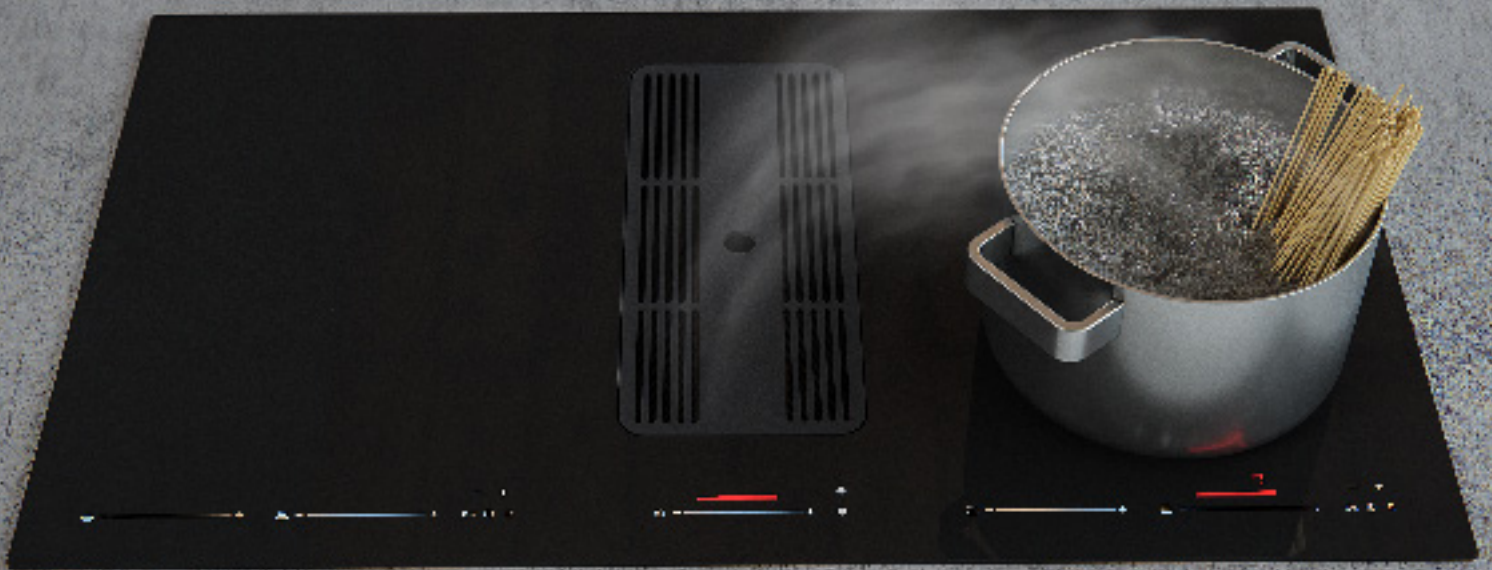

INTEGRATED EXTRACTION HOB

Sddh3 + SEM 10 - SEM 12

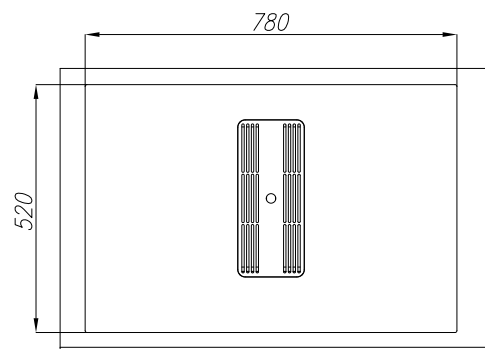
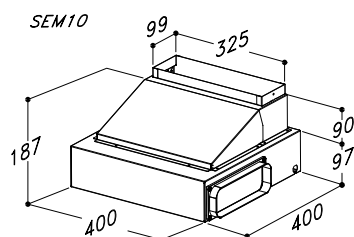
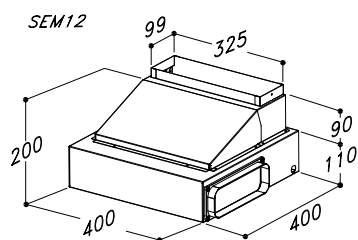
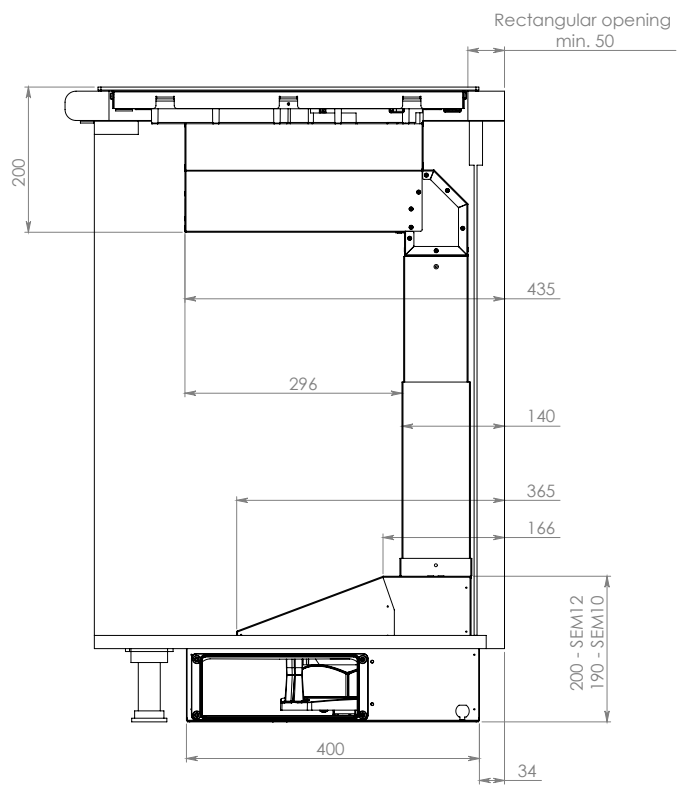
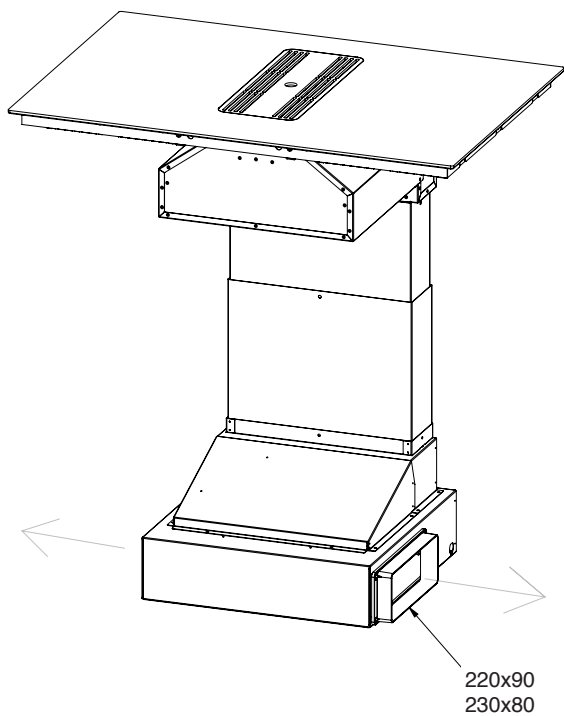

TECHNOLOGY

- Induction G5
- Beveled edges black glass
- Automatic heat-up function
- Safety Lock
- Timer function
- Over-heating operation
- "Keep Warm" function
- Pause and recall function
- Bridge function
- Touch Controls
- Booster function on all zones
- Cooking output
- 4 zones (SH3-SH1) 184X220mm: 2100W; Power:3700W
- Power:3700W
- Max Power: 7.4 kW
- Electric rating: 220-240 V (50/60 Hz)

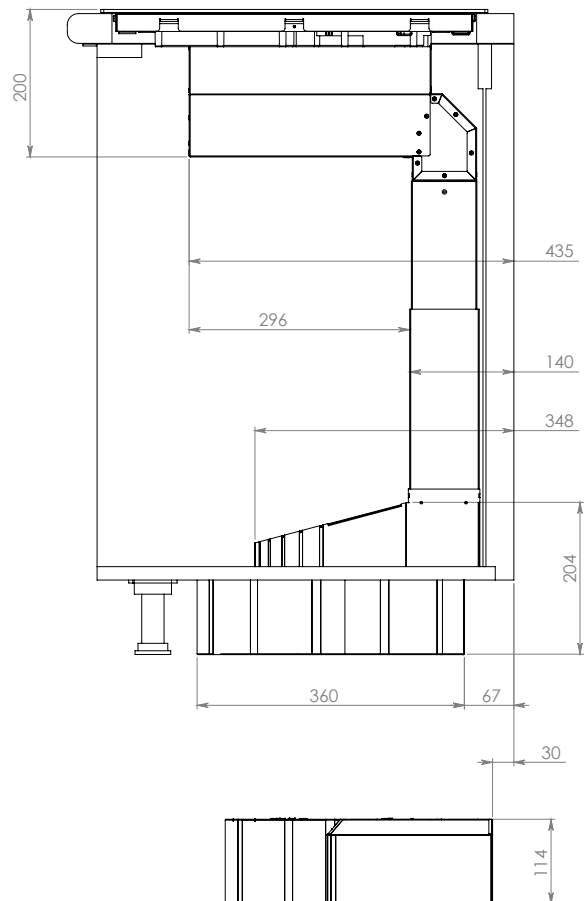
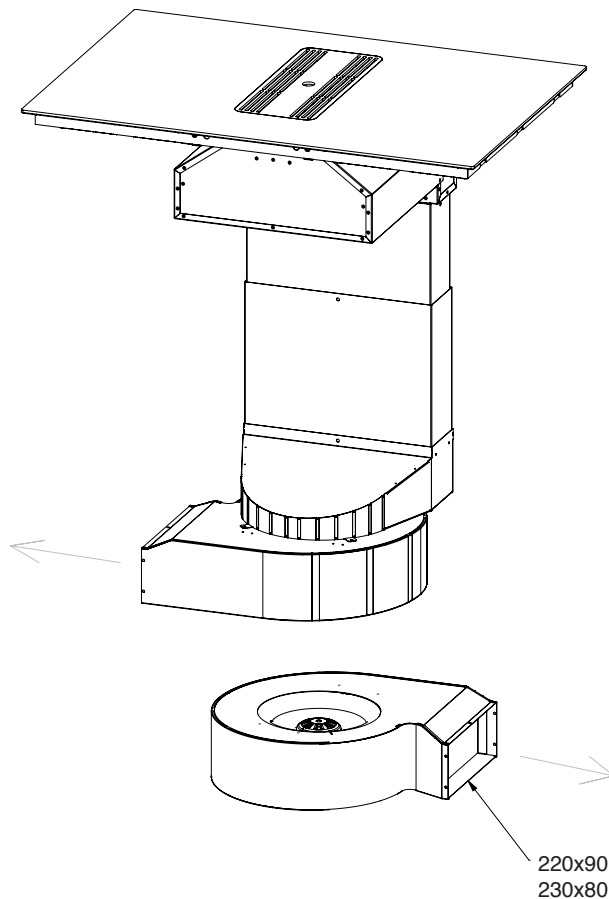

Sddh3 + SEM 16

SDDH3+SEM16				SDDH3+SEM10				SDDH3+SEM12			
	Q [m3/h]	db [A]	V [m/s]		Q [m3/h]	db [A]	V [m/s]		Q [m3/h]	db [A]	V [m/s]
1°	320	55	4	1°	274	54	3	1°	296	52	4
2°	410	56	5	2°	374	59	4	2°	370	62	5
3°	560	62	7	3°	475	63	5	3°	478	67	7
4°	725	69	9	4°	556	68	7	4°	700	72	9

EEC A+

EEC B

EEC B



Sddh 5

Motor:

external motor (to be purchased separately)

Control panel:

Touch control 4 speeds + timer on the induction hob

Filter:

Patented anodized aluminum filter with oil collector

Anti-crushing safety system

Suction opening by 45° and 90°

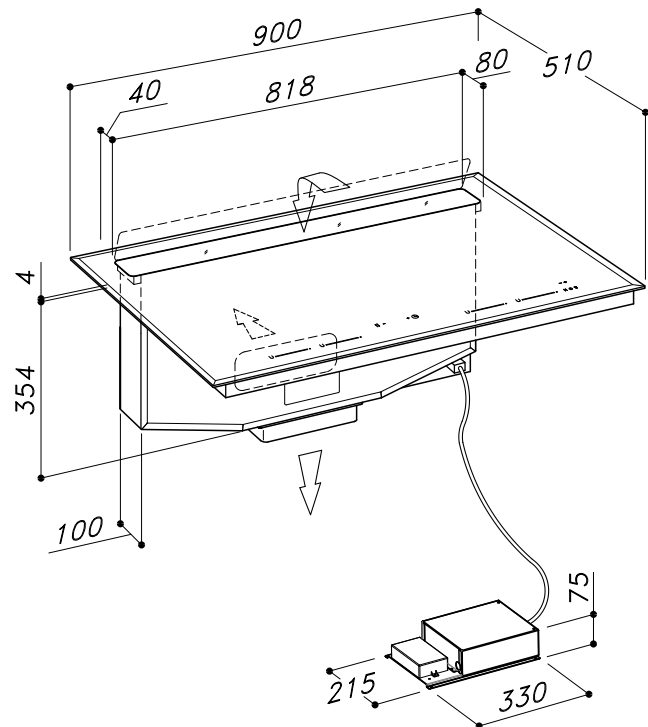

Motor Type	EEl CLASS	AEChood (KWh/a)	FDE CLASS	LE CLASS	GFE CLASS	dB(A) BOOST speed	Qmax (mc/h) 50	Lighting
SEM1	A	47,5	B	n/a	C	66	600	no
SEM2	B	73,6	C	n/a	D	68	582	no
SEM10	B	52,1	C	n/a	C	70	484	no
SEM12	B	73,6	C	n/a	C	71	577	no



Sh 4 Connectivity Induction



CONNECTIVITY

This System enables the customer to control the hood automatically from the hob.

Moreover, it allows to adjust the suction power of the hood according to the heating level of the cooking surface.

TECHNOLOGY

- Flexi square Induction
- Beveled edges black glass
- Touch Controls
- Integrated electronic display
- 9 power levels
- Safety Lock
- Pan Detection
- Residual heat indicator
- Booster function on all zones
- Double booster on all zones
- Timer function on all zones
- Automatic Cooking
- Recall function
- "Stop & Go" function
- "Keep Warm" function
- Automatic cooking sensor 42°C / 70°C
- Automatic boiling Sensor 94°C
- Bridge and Automatic Bridge Function
- 2 zones 220X180mm: 2100W; Booster: 2600W; Double Booster: 3700W
- 1xø260 mm: 2600W; Booster: 3200W; Double Booster: 3700W
- 1xø210 mm: 2300W; Booster: 2900W; Double Booster: 3700W
- Max Power: 7.4 kW
- Electric rating: 220-240 V (50/60 Hz)

Sddh1



DOWNDRAFT TECHNICAL DATA:

- Motor:** 1000 m3/h (not included)
Available also in external motor
- Lighting:** 1x5 W LED strip
- Control panel:** Touch Control 4 speeds on the Induction Hob
- Filter:** anodized aluminum (4+1)
- Stainless steel:** AISI 304

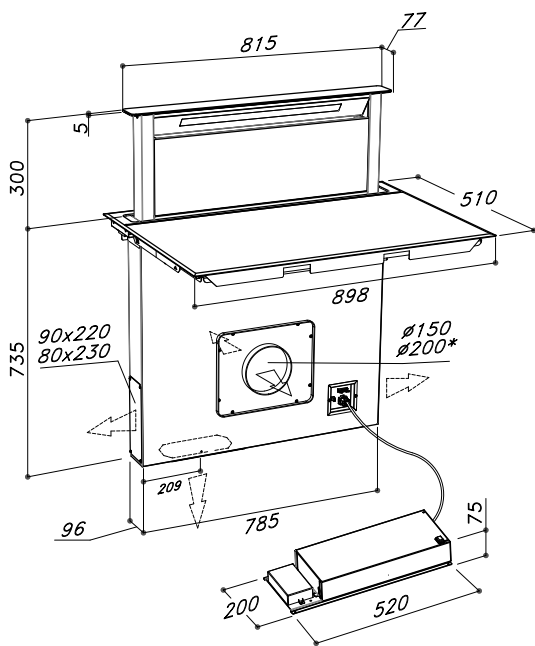

* accessory outlet Ø200mm
Cut out: 860x490 mm

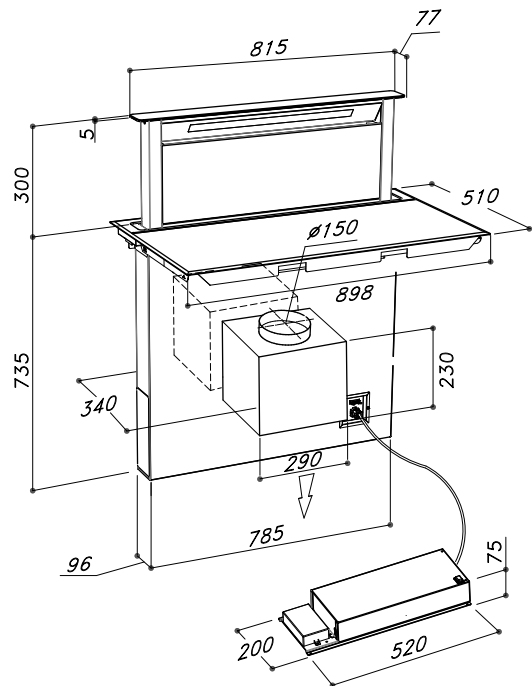

Cut out: 860x490mm

Motor Type	EEI CLASS	AEchood (KW/h/a)	FDE CLASS	LE CLASS	GFE CLASS	dB(A) BOOST speed	Qmax (mc/h) 50	W
on-board	A	44,5	A	A	E	68	757	1x5
SEM1	B	54,5	A	A	E	59	682	1x5
SEM2	C	82,9	C	A	E	62	731	1x5
SEM8	C	102,6	B	A	F	64	753	1x5
SEM10	C	54,3	C	A	E	61	530	1x5
SEM12	B	65,2	A	A	E	68	668	1x5

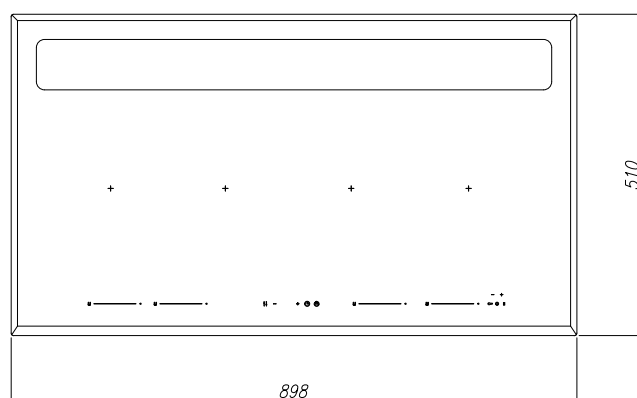



Sirius
● ○ ●

Zona Ind.le Berbentina 6/a
60041 SASSOFERRATO (An)
tel. 0732.97171 fax. 0732.95493
siriuscappe@siriuscappe.com

www.siriuscappe.com